

# 12VDC AXIAL MOTOR FANS

FAN DIAMETER  
16" [385mm]

## MODEL INFORMATION\*

PART#	TYPE**	VOLTS	WATTS	BLADE	MATERIAL
G-4016-A	REVERSIBLE	12VDC	225W	"S"	MFGF NYLON

\*ALSO AVAILABLE IN 24VDC      \*\*SET UP AS PULLER FROM FACTORY



**WATER & DUST RESISTANT**

## REVERSIBLE

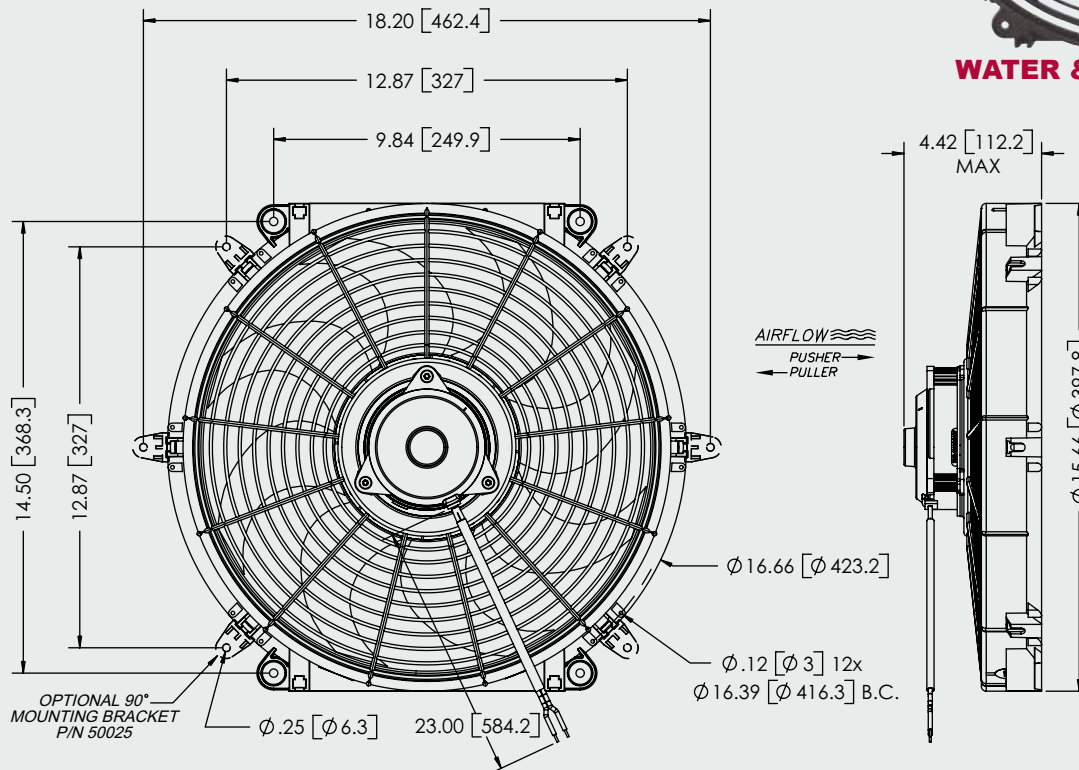

16" MED PROFILE

## TYPICAL AIR PERFORMANCE @ 13.5VDC

16" 225W "S" BLADE PULLER/PUSHER FANS

STATIC PRESSURE IN H <sub>2</sub> O	STATIC PRESSURE mm H <sub>2</sub> O	CFM	m <sup>3</sup> /h	Amps
0	0.0	1746	2966	12.9
0.1	2.5	1604	2725	13.3
0.2	5	1336	2316	13.3
0.3	7.5	798	1356	12.5
0.4	10	598	1016	13.1
0.5	12.5	343	583	13.1
0.6	15	125	212	13.7

STALL @ 0.67" [17mm] - 14.3 Amps

