

FAN DIAMETER
9" [225mm]

12VDC AXIAL MOTOR FANS



IP68

MODEL INFORMATION

PART#	TYPE*	VOLTS	WATTS	BLADE	MATERIAL
TA09R2002	REVERSIBLE	12VDC	130W	"S"	GF NYLON
TB09R2002	REVERSIBLE	24VDC	"S"	GF NYLON	

*SET UP AS PULLER FROM FACTORY

REVERSIBLE

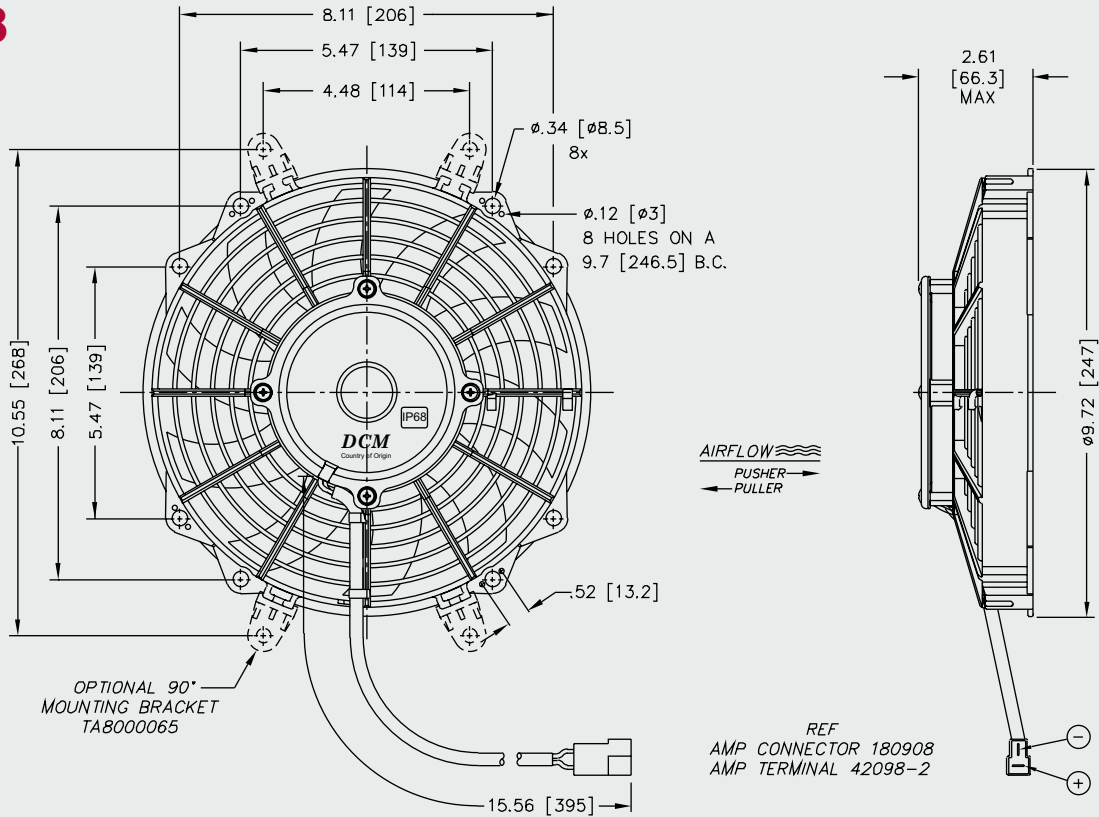

TYPICAL AIR PERFORMANCE @ 13.5VDC 9" 130W "S" BLADE PULLER/PUSHER FANS

STATIC PRESSURE IN H ₂ O	STATIC PRESSURE mm H ₂ O	CFM	m ³ /h	Amps
0	0.0	737	1252	7.7
0.1	2.5	692	1176	8.0
0.2	5	629	1069	8.2
0.3	7.5	554	941	8.3
0.4	10	476	809	8.3
0.5	12.5	399	678	8.3
0.6	15	326	554	8.3
0.7	17.5	259	440	8.3
0.8	20	197	334	8.5
0.9	22.5	141	240	8.7
1.0	25	85	144	9.1

STALL @ 1.1" [27.9mm] - 9.9 Amps

