

# IMPELLER WHEELS

DOUBLE INLET

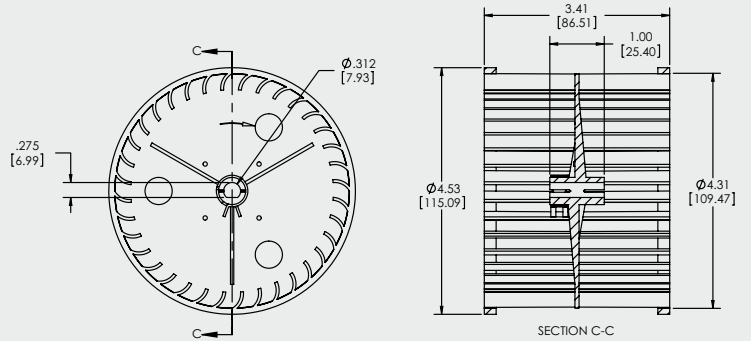

## MODEL 2364 DOUBLE INLET WHEEL

PART#*	VANES PER SIDE	MATERIAL**
R-2042-A	36 IN-LINE	GFPP

\*NOT AVAILABLE IN ALL MARKETS

\*\*OTHER MATERIALS AVAILABLE UPON REQUEST

PRESSURE	HORSEPOWER	SPEED
		3450 RPM
		1725 RPM
		1550 RPM
		1000 RPM

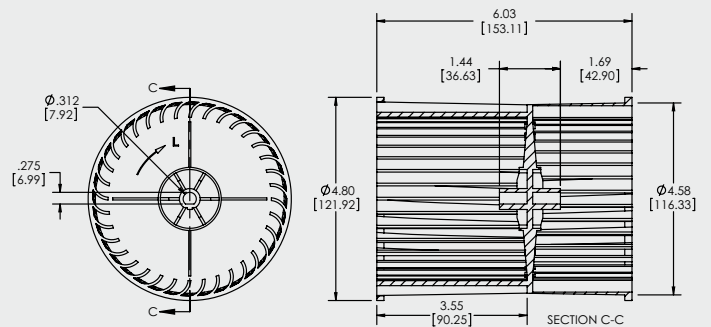
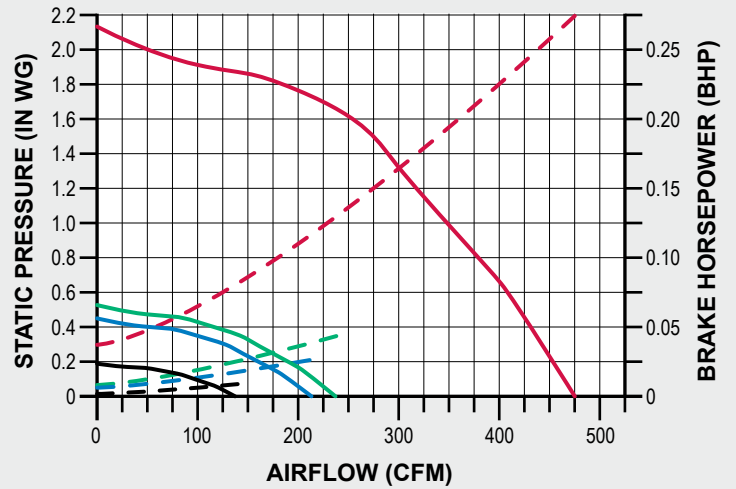

## MODEL 2403 DOUBLE INLET WHEEL

PART#	SIDE*	VANES PER SIDE	MATERIAL**
2403L	LEFT	36 STAGGERED	ABS
2403R	RIGHT	36 STAGGERED	ABS

\*RIGHT AND LEFT MUST BE SOLD AS SET

\*\*OTHER MATERIALS AVAILABLE UPON REQUEST