

# IMPELLER WHEELS

## DOUBLE INLET

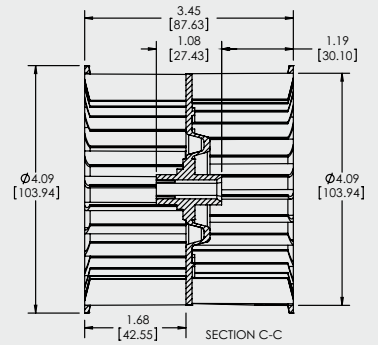
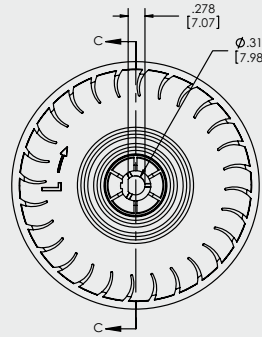

MODEL 2090 DOUBLE INLET WHEEL			
PART#*	SIDE**	VANES PER SIDE	MATERIAL ***
2090L-N	LEFT	28 STAGGERED	GFPP
2090R-N	RIGHT	28 STAGGERED	GFPP
*CLIP CS4 NOT INCLUDED			
**RIGHT AND LEFT MUST BE SOLD AS SET			
***OTHER MATERIALS AVAILABLE UPON REQUEST			

PRESSURE	HORSEPOWER	SPEED
		3450 RPM
		1725 RPM
		1550 RPM
		1000 RPM

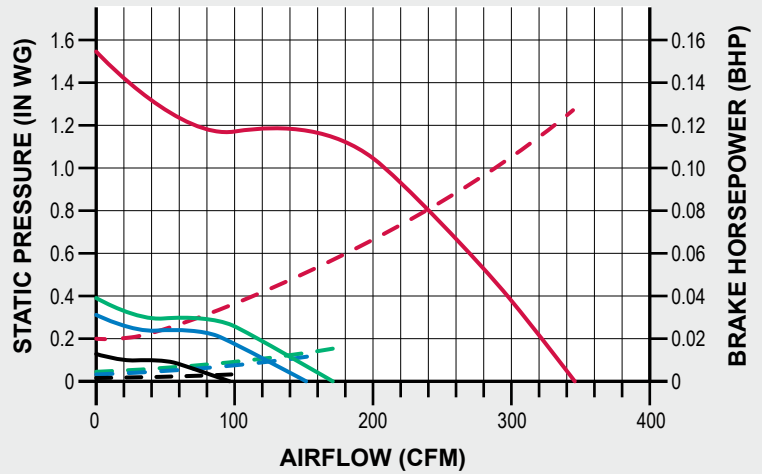

MODEL 2207 DOUBLE INLET WHEEL				
PART#	VANES PER SIDE	A	B	MATERIAL*
2207	24 IN-LINE	Ø.312 [7.92]	.294 [7.47]	GFN
2207-1	24 IN-LINE	Ø.376 [9.55]	.326 [8.28]	GFN
*OTHER MATERIALS AVAILABLE UPON REQUEST				

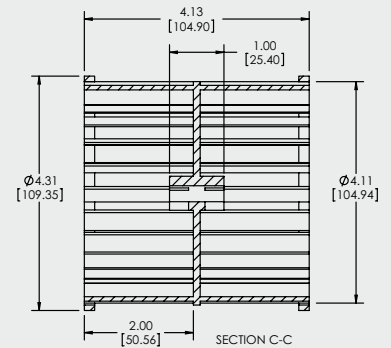
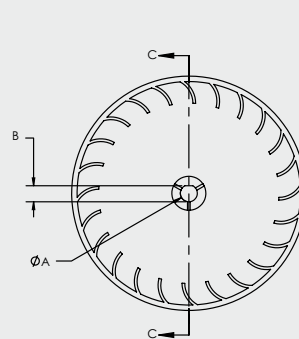

PRESSURE	HORSEPOWER	SPEED
		3450 RPM
		1725 RPM
		1550 RPM
		1000 RPM

