

SINGLE INLET

IMPELLER WHEELS

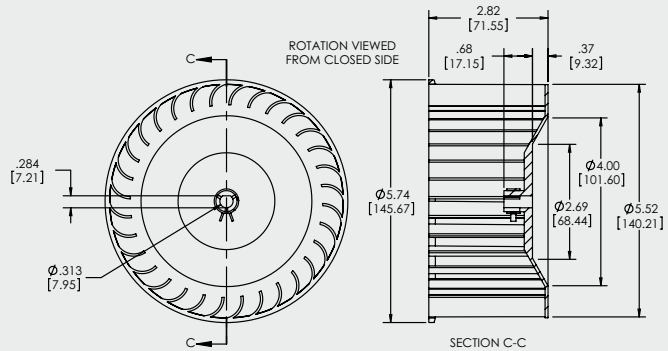

MODEL 2165 SINGLE INLET WHEEL			
PART#*	VANES	ROTATION	MATERIAL**
2165-A	32	CCW	GFPP
*INCLUDES CLIP CS4			
**OTHER MATERIALS AVAILABLE UPON REQUEST			

PRESSURE	HORSEPOWER	SPEED
		1550 RPM
		1140 RPM
		1050 RPM
		1000 RPM

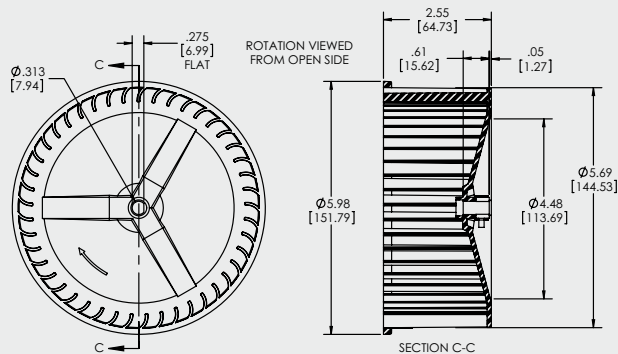
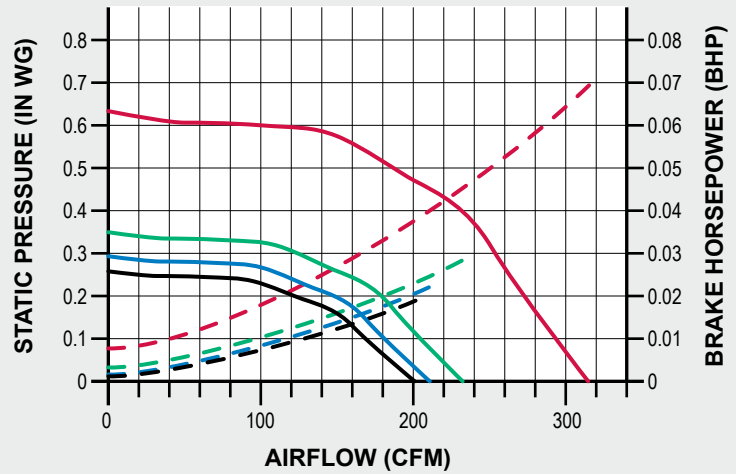

MODEL 2111 & 2112 SINGLE INLET WHEEL			
PART#*	VANES	ROTATION	MATERIAL**
2111-A	45	CCW	ABS
2112-A	45	CW	ABS
*INCLUDES CLIP CS4			
**OTHER MATERIALS AVAILABLE UPON REQUEST			

PRESSURE	HORSEPOWER	SPEED
		3450 RPM
		1725 RPM
		1550 RPM
		1000 RPM

