

# IMPELLER WHEELS

## SINGLE INLET

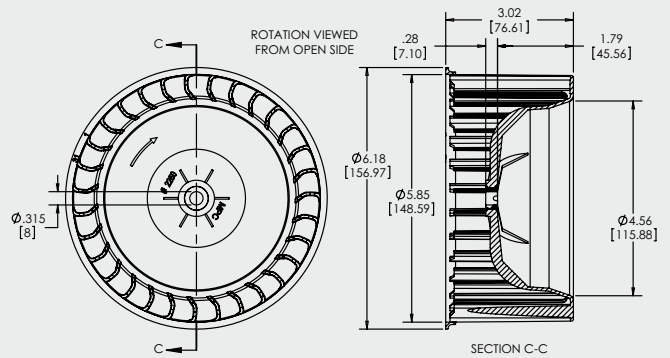

### MODEL 2250 & 2251 SINGLE INLET WHEEL

PART#	VANES	ROTATION	MATERIAL*
2250-GFN	31	CW	GFN
2251-GFN	31	CCW	GFN

\*OTHER MATERIALS AVAILABLE UPON REQUEST

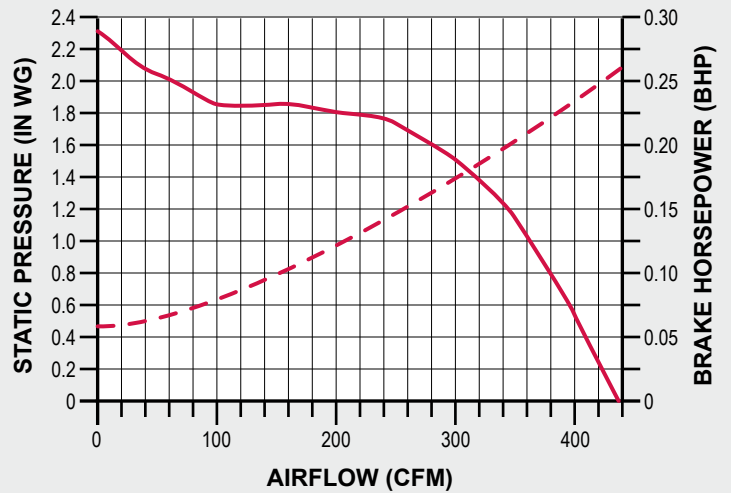

### BORE DIMENSIONS

PART#	A	B
2159-A	Ø.500 [12.70]	.458 [11.63]
2159-2	Ø.313 [7.94]	.270 [6.86]
2316	Ø.313 [7.94]	.270 [6.86]

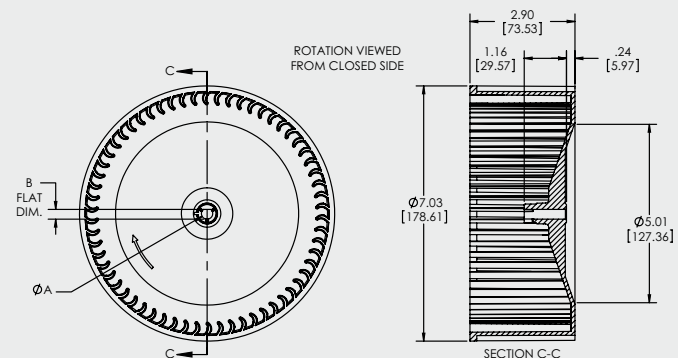

### MODEL 2159 & 2316 SINGLE INLET WHEEL

PART#*	VANES	ROTATION	MATERIAL**
2159-A	62	CW w/CLAMP	CCPP
2316	62	CCW w/CLAMP	CCPP

\*INCLUDES CLIP CS5

\*\*OTHER MATERIALS AVAILABLE UPON REQUEST

